

# Technical Data sheet - Lightning Stair Nose

## SNLD Series

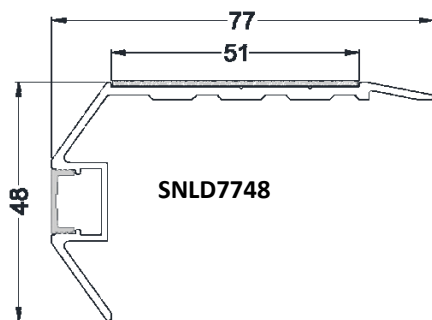

SNLD7748



End Cap

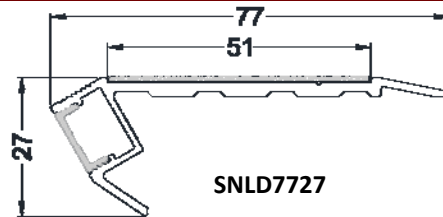

SNLD7727



End Cap

**Lightning Stair Nose Series** incorporating a range of anti-slip inserts with the light out configuration.

Complete with frosted polycarbonate diffuser to ensure optimum light dispersion.

### Aluminium Details

European Standard	<b>EN573-3</b>
British Standard	<b>BS1474</b>
American Standard	<b>ASTM B221</b>
Australian Standard	<b>AS/NZ1866</b>
Alloy	<b>6063</b>
Temper	<b>T5</b>
Composition : Si%	<b>0.2-0.6</b>
Composition : Fe%	<b>0.35</b>
Composition : Cu%	<b>0.1</b>
Composition : Mn%	<b>0.1</b>
Composition : Mg%	<b>0.45-0.90</b>
Composition : Zn%	<b>0.1</b>
Composition : Ti%	<b>0.1</b>
Composition : Cr%	<b>0.1</b>
Composition : Al%	<b>Balance</b>
Tensile Strength <3mm (N/mm <sup>2</sup> )	<b>175</b>
0.2% Proof Stress <3mm (N/mm <sup>2</sup> )	<b>130</b>
Elongation <3mm (%)	<b>8</b>
Flammability	Solid Aluminium is non-combustible material. Does not burn, does not give off smoke when exposed to fire and does not emit sparks on impact.

### Polycarbonate (Lexan 153) Details

Description	Test Methods	Typical Values
Melt Flow Rate	ASTM D1238	<b>2.5 gm/10 min</b>
Density	ASTM D1505	<b>1.2 gm/cm<sup>3</sup></b>
Tensile Strength @ Yield	ASTM D638	<b>65 MPa</b>
Tensile Strength @ Break	ASTM D638	<b>110 MPa</b>
Flexural Strength	ASTM D790	<b>93 MPa</b>
Flexural Modulus	ASTM D790	<b>2343 MPa</b>
Izod Impact (notched @23°C)	ASTM D256	<b>29.7 kJ/m<sup>2</sup></b>
Heat Deflection Temp @ 0.45 MPa	ASTM D648	<b>137 °C</b>
Vicat Softening Temp, Rate B	ASTM D1525	<b>157 °C</b>
UL94HB Flame Class Rating	UL94	<b>1.6 mm</b>
Water Absorption at 3.2mm	ASTM D570	<b>0.15 %</b>
Mould Shrinkage	ASTM D955	<b>5 -7 <sup>-3</sup>mm/mm</b>

### Head Office & Factory

92, 92/1-4 Moo1, Homsin, Bangpakong, Cha-Choeng-Sao, 24130 Thailand  
Tel : +66 38 842 749 Email : contact@alusite.com



# Technical Data sheet - Lightning Stair Nose

## SNLD Series

### Silicon Carbide Anti Slip (Passed High Slip Resistance)

Slip resistance classification Appendix A: WET Pendulum (Four S slider): Mean BPN: 73 V	AS/NZS 4586	[HIGH*]
Slip resistance classification Appendix D: OIL-WET Ramp Mean overall acceptance angle: 38.1° R 13	AS/NZS 4586	[HIGH*]

### Laboratory Test Details

Toxicity and Heavy Metal (RoHS)	ISO 3613	Passed
Toxicity and Heavy Metal (RoHS)	US EPA 3052 & 6010B	Passed
Salt Spray (Corrosion Test)	ASTM B 117-03	240 Hrs
Accelerated Weathering test	ASTM G154	1,000 Hrs
Water Splash Resistant	Rated IPX4 under IEC standard 60529	Passed

### Maintenance

Alusite Series utilizes 6063 aluminium alloy commonly used for building material. As with any finished building material, anodized aluminum requires reasonable care prior to and during installation and periodic cleaning and maintenance after installation. Although anodized aluminum possesses exceptional resistance to corrosion, discoloration, and wear, its natural beauty can be marred by harsh chemicals, rough conditions or neglect. Such conditions usually affect only the surface finish and do not reduce the service life of the aluminum. However, scratching and wear and may be damaged by tile adhesive, mortar, or grouting material. Therefore, setting materials must be removed with a sponge and warm water immediately.

### Precautions

Remove and clean adhesive or grout residue from visible surfaces immediately. Avoid using aggressive alkaline or acid cleaners on aluminum finishes. Do not use cleaners containing trisodium phosphate, phosphoric acid, hydrochloric acid, hydrofluoric acid, fluorides, or similar compounds on anodized aluminum surfaces. Strong solvents or abrasive cleaners can cause damage to painted surfaces. Always follow the cleaner manufacturer's recommendations as to the proper cleaner and concentration. Test-clean a small area first. Different cleaners should not be mixed.

#### Head Office & Factory

92, 92/1-4 Moo1, Homsin, Bangpakong, Cha-Choeng-Sao, 24130 Thailand  
Tel : +66 38 842 749 Email : contact@alusite.com

